

ACVATIX™

Electromotoric actuators for stroke valves

SAS..



Electromotoric actuators with 5.5 mm stroke and 400 N positioning force

- SAS31.. Operating voltage AC 230 V, 3-position control signal
- SAS61.. Operating voltage AC 24 V / DC 24 V, positioning signal DC 0...10 V / DC 4...20 mA / 0...1000 Ω
- SAS61../MO operating voltage AC 24 V / DC 24 V, RS485 for Modbus RTU communication
- SAS81.. Operating voltage AC/DC 24 V, 3-position control signal
- For direct mounting on valves; no adjustments required
- Manual adjuster, position and status indication (LED)
- Optional function extension with auxiliary switch

Application

To operate Siemens 2-port and 3-port valves:

- Types V..G44.., VVG55.., and VVG549..
- 5.5 mm stroke

Used as control and shutoff valves in heating and ventilation plants.

Together with the ASK30 mounting kit, all former Landis & Gyr valves with 4 mm or 5.5 mm stroke can also be operated: X3i.., VVG45.., VXG45.., VXG46.., VVI51...

Functions

Function	Description	Type
3-position control	A 3-position signal controls the actuator via connection terminals Y1 or Y2. The desired position is transmitted to the valve.	SAS31.. SAS81..
Modulating control	The modulating positioning signal provides stepless motor control. The positioning signal range (DC 0...10 V / DC 4...20 mA / 0...1000 Ω) corresponds to the positioning range (closed...open, or 0...100% stroke) in a linear manner.	SAS61..
Positioning signal and characteristic changeover	Setting with DIL switch. Factory setting SAS.: <ul style="list-style-type: none"> • Characteristic curve: log = Equal percentage (switch set to Off) • Positioning signal: DC 0...10 V (switch set to Off) 	
Position feedback U	Signal returned to acquire the position via input.	
Forced control (Z-mode)	Forced control helps override automatic mode and is implemented via higher control.	
Calibration	Carry out during initial commissioning. The actuator drives to the top or bottom end position; the measured values are saved.	SAS61.. SAS61../MO
Valve seat detection	The actuators have power-dependent seat detection. After calibration, the exact valve stroke is stored in the actuator's memory.	
Foreign body detection	After clogging is detected, three attempts are made to get past clogging. If unsuccessful, the actuator continues to following the positioning signal only within a limited range, and the LED shines red.	
Modbus RTU (RS-485), not galvanically isolated	Setpoint 0..100% valve position Actual value 0..100% for valve position Override control Open / Close / Min / Max / Stop Setpoint monitoring and backup mode	SAS61../MO

Types

Type	Item no.	Operating voltage	Control signal	Power consumption	Pos. time	Spring return func./time	Manual adjustment	Position feedback	Comment		
SAS31.00	S55158-A106	AC 230 V	3-position	2.8 / 2.4 VA ⁵⁾	120 s	No / –	Yes	-	1) 3)		
SAS31.03	S55158-A107			3.5 / 2.9 VA ⁵⁾	30 s						
SAS31.50	S55158-A108			3.5 / 2.9 VA ⁵⁾	120 s	Yes / <28 s ⁶⁾	No				
SAS31.53	S55158-A109			5.5 / 3.8 VA ⁵⁾	30 s	Yes / <14 s ⁶⁾					
SAS61.03	S55158-A100	AC / DC 24 V	DC 0...10 V	5.3 / 4.5 VA ⁵⁾	30 s	No / –	Yes	DC 0...10 V	1) 4)		
SAS61.03U	S55158-A100-A100		DC 4...20 mA 0...1000 Ω	5.3 / 4.5 VA ⁵⁾							
SAS61.03/MO	S55158-A121		Modbus RTU	6.0 / 5.2 VA ⁵⁾				Modbus RTU	1) 7)		
SAS61.33	S55158-A101		DC 0...10 V	5.9 / 4.8 VA ⁵⁾						DC 0...10 V	1)
SAS61.33U	S55158-A101-A100		DC 4...20 mA 0...1000 Ω	5.9 / 4.8 VA ⁵⁾		Yes / <14 s ⁶⁾	2)				
SAS61.53	S55158-A102		5.8 / 5.0 VA ⁵⁾	No		1)					
SAS81.00	S55158-A103		AC / DC 24 V	3-position		2.2 / 2.0 VA ⁵⁾	120 s	No / –	Yes	-	1)
SAS81.03	S55158-A104					2.5 / 2.1 VA ⁵⁾	30 s				
SAS81.03U	S55158-A104-A100	2.5 / 2.1 VA ⁵⁾			Yes / <14 s ⁶⁾	2)					
SAS81.33	S55158-A105	3.4 / 2.4 VA ⁵⁾				1)					
SAS81.33U	S55158-A105-A100	3.4 / 2.4 VA ⁵⁾				2)					

1) Cable gland: M16, M20 (ISO50262)

2) Cable gland ½" (UL514C)

3) Approbation: CE

4) Approbation: CE, UL (only 24 V)

5) Second value: Power consumption in normal position

6) Spring return time at low temperatures slightly longer

7) Fixed connection cable 5 x 0.75 mm²

Delivery

Actuators, valves, and accessories are supplied in individual packs.

Accessories

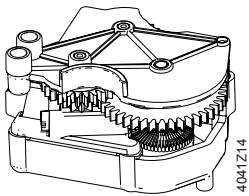
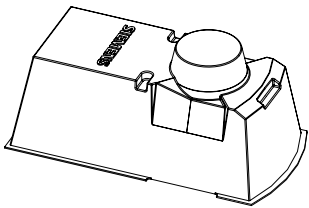
Electrical accessories	Mechanical accessory
Auxiliary switch ASC10.51 	Weather shield ¹⁾ ASK39.2 

1) SAS61.../MO is not intended for outdoor use

Ordering (example)

Type	Stock number	Designation	Number of pieces
SAS31.00	S55158-A106	Actuator	1
+ auxiliary components such as connections, aux switches, etc.			

Spare parts

Stock number	Description
S55845-Z180	Type ASQ1: Housing cover with associated screws and light guide as component, without laser labeling

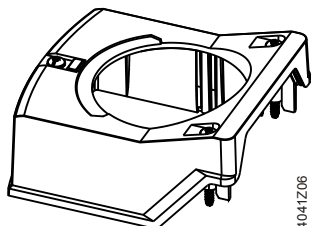

Compatibility

Valves PN16					Actuators SAS..	
VVG44.. (2-port)	VXG44.. (3-port)	DN	G	k _{vs}	Δp _s	Δp _{max}
Medium: 1...120 °C			[inch]	[m ³ /h]	[kPa]	[kPa]
VVG44.15-.. ¹⁾	VXG44.15-.. ¹⁾	15	G 1 B	0,25 / 0,4 / 0,63	1600	400
VVG44.15-.. ¹⁾	VXG44.15-.. ¹⁾	15	G 1 B	1 / 1,6	725	400
VVG44.15-.. ¹⁾	VXG44.15-.. ¹⁾	15	G 1 B	2,5 / 4	400	400
VVG44.20-6.3	VXG44.20-6.3	20	G 1 ¼ B	6,3	750	400
VVG44.25-10	VXG44.25-10	25	G 1 ½ B	10	400	400
VVG44.32-16	VXG44.32-16	32	G 2 B	16	250	250
VVG44.40-25	VXG44.40-25	40	G 2 ¼ B	25	125	125

¹⁾ = use k_{vs} value

Valves PN25					Actuators SAS.. ¹⁾	
VVG549. (2-port)		DN	G	k _{vs}	Δp _s	Δp _{max}
Medium: 1...130 °C			[inch]	[m ³ /h]	[kPa]	[kPa]
VVG549.15-0.25		15	G ¾ B	0,25	2500	1200
VVG549.15-0.4		15	G ¾ B	0,4	2500	1200
VVG549.15-0.63		15	G ¾ B	0,63	2500	1200
VVG549.15-1		15	G ¾ B	1,0	1500	1200
VVG549.15-1.6		15	G ¾ B	1,6	1500	1200
VVG549.15-2.5		15	G ¾ B	2,5	1500	1200
Pressure compensated						
VVG549.20-4K		20	G 1 B	4,0	1600	1200
VVG549.25-6.3K		25	G 1 ¼ B	6,3	1600	1200

¹⁾ SAS.. combined with VVG549: Change DIL switch setting to linear (factory setting = log).

SAS../MO: Change Modbus register 263 to 0 = linear → only possible with Firmware release 2.0, not with 0.27 and 1.0!

Valves PN25					Actuators SAS..	
VVG55.. (2-port) ¹⁾		DN	G	k _{vs}	Δp _s	Δp _{max}
Medium: 1...130 °C			[inch]	[m ³ /h]	[kPa]	[kPa]
VVG55.15-.. ²⁾		15	G ¾ B	0,25 / 0,4 / 0,63	2500	1200
VVG55.15-.. ²⁾		15	G ¾ B	1 / 1,6 / 2,5	2000	1200
VVG55.20-4		20	G 1 B	4	1000	1000
VVG55.25-6.3		25	G 1 ¼ B	6,3	800	800

¹⁾ VVG55 is replaced by VVG549 from Jan 1, 2017.

²⁾ = use k_{vs} value

Product documentation

Title	Content	Document ID
Actuators SAS.., SAT.. for valves	Basic documentation: Comprehensive information on actuators SAS..	CE1P4041
Electromotive actuators for valves SAS..	Data sheet: Product description SAS..	CE1N4581
Electromotive actuators for valves SA.., Modbus RTU	Data sheet: Modbus communication profiles	A6V101037195
Mounting instructions S..6../MO and G..161../MO	Mounting instructions: Mounting and installation instructions	A5W00027551

Related documents such as environmental declarations, CE declarations, etc., can be downloaded at the following Internet address: <http://siemens.com/bt/download>

Notes

Safety

	⚠ CAUTION
	National safety regulations Failure to comply with national safety regulations may result in personal injury and property damage. <ul style="list-style-type: none">• Observe national provisions and comply with the appropriate safety regulations.

Engineering

SAS31.. and SAS81..

3-position actuators must have their own specific controller, see "Conenction Diagrams".

SAS61..

Up to 10 actuators can drive in parallel on a controller output with a rating of 1 mA. Modulating actuators have an input impedance of 100 kΩ.

SAS61../MO

The Modbus converter is dimensioned for analog control at 0..10 V.

Note: Keep the analog signal setting on the actuator as is (switch 1 to Off); adjustment not possible.

The actuators are parameterized at the factory to an equal-percentage characteristic; this corresponds to their use with valves VVG/VXG44.

When using SAS61.03/MO with valve series VVG549, the following must be set:

- Actuator: DIL switch (internal actuator characteristic changeover) to linear (switch 2 to On).
- Modbus register 263: Set "Y_U_Characteristic" to "0 = linear".

Mounting positions

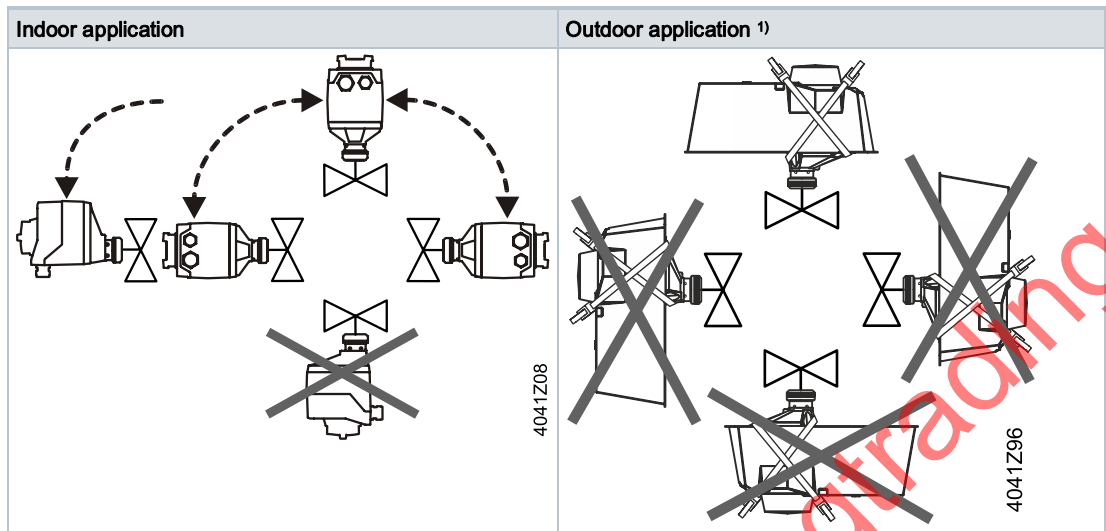

¹⁾ Only together with weather shield ASK39.2. IP54 housing protection unchanged. SAS61../MO is not intended for outdoor use.

Maintenance

The SAS.. actuators are maintenance-free.

Mounting:

- Do not touch the valve coupling if the components (valve/pipes) are hot
- If necessary, disconnect electrical connections from the terminals

The actuator must be correctly fitted to the valve before recommissioning.

Disposal

	<p>⚠ WARNING</p>
	<p>Tensioned return spring Opening the actuator housing can release the tensioned return spring resulting in flying parts that may cause injury.</p> <ul style="list-style-type: none"> • Do not open the actuator body.
	<p>The device is considered electrical and electronic equipment for disposal in terms of the applicable European Directive and may not be disposed of as domestic garbage.</p> <ul style="list-style-type: none"> • Dispose of the device through channels provided for this purpose. • Comply with all local and currently applicable laws and regulations.

Warranty

Technical data on specific applications are valid only together with Siemens products listed under "Equipment combinations". Siemens rejects any and all warranties in the event that third-party products are used.

Note

When using the actuators in connection with valves of other manufacture, correct functioning must be ensured by the user, and Siemens will assume no responsibility.

Technical data

Power supply		SAS..
Operating voltage	SAS31..	AC 230 V \pm 15%
	SAS61..	AC 24 V \pm 20% / DC 24 V +20% / -15% or AC 24 V class 2 (US)
	SAS81..	AC/DC 24 V \pm 20 % or AC 24 V class 2 (US)
Frequency		45...65 Hz
External supply line fusing (EU)		Fuse slow 6 A...10 A or fuse switch max. 13 A, release characteristic B,C,D as per EN 60898 power source with current limitation of max. 10 A
Power consumption	At 50 Hz	See "Type summary"; stem retracts/extends

Function data		
Positioning time for nominal stroke	SAS..0	120 s
	SAS..3 / SAS..3U	30 s
Positioning force		400 N
Nominal stroke		5.5 mm
Permissible medium temperature	With valve	1...130 °C

Signal inputs		
Y1 / Y2	SAS31.., SAS81..	3-position
	SAS31..	Voltage AC 230 V \pm 15%
	SAS81..	Voltage AC 24 V \pm 20% / DC 24 V + 20% / - 15%
Positioning signal "Y"	SAS61..	DC 0...10 V / DC 4...20 mA / 0...1000 Ω
	SAS61.. (DC 0...10 V) current draw	\leq 0.1 mA
	Input impedance	\geq 100 k Ω
	SAS61.. (DC 4...20 mA) current draw	DC 4...20 mA \pm 1%
	Input impedance	\leq 500 Ω

Communication SAS61../MO		
Communication protocol	Modbus RTU	RS-485, not galvanically isolated
	Number of nodes	Max. 32
	Address range	1...247 / 255 Factory setting: 255
	Transmission formats	1-8-E-1 / 1-8-O-1 / 1-8-N-1 / 1-8-N-2 Factory setting: 1-8-E-1
	Baud rates (kbaud)	Auto / 9.6 / 19.2 / 38.4 / 57.6 / 76.8 / 115.2 Factory setting: Auto
	Bus termination	120 Ω electronically switchable Factory setting: Off

Parallel connection		
	SAS61..	\leq 10 (depending on controller output)

Forced control		
Z positioning signal	SAS61..	R = 0...1000 Ω , G, G0
	R = 0...1000 Ω	Stroke proportional to R
	Z connected to G	Max. stroke 100%

Forced control		
	Z connected to G0	Min. stroke 0%
	Voltage	Max. AC 24 V $\pm 20\%$ / Max. DC 24 V $+20\%$ / -15%
	Current draw	≤ 0.1 mA

Position feedback		
U	Voltage range SAS61..	DC 0...10 V
	Load impedance	> 10 k Ω resistive
	Load	Max. 1 mA

Connection cables		
Wire cross-sectional areas		0.75...1.5 mm ² , AWG 20...16 ¹⁾
Cable entries	SAS.. (EU)	1 entry dia. 16.4 mm (für M16) 1 entry dia. 20.5 mm (für M20) Thread length max. 9mm
	SAS..U (US)	2 entries dia. 21.5 mm for 1/2" tube connection
	SAS61../MO	Fixed connection cable 0.9m Number of cores 5 x 0.75 mm ²

Protection class		
Housing	See "Mounting"	IP 54 as per EN 60529
Insulation class		As per EN 60730
	Actuators SAS31.. AC 230 V	II
	Actuators SAS61.. AC / DC 24 V	III
	Actuators SAS81.. AC / DC 24 V	III

Environmental conditions		
Operation		IEC 60721-3-3
	Climatic conditions	Class 3K5
	Mounting location	Indoors, outdoors ²⁾
	Temperature, general	-5...55 °C
	Humidity (non-condensing)	5...95 % r. h.
Transport		IEC 60721-3-2
	Climatic conditions	Class 2K3
	Temperature	-25...70 °C
	Humidity	< 95 % r. h.
Storage		IEC 60721-3-1
	Temperature	-15...55 °C
	Humidity	5...95 % r. h.

Standards	
Product standard	EN60730-x
Electromagnetic compatibility (field of use)	For residential, commercial and industrial environment
EU conformity (CE)	CE1T4581xx ³⁾ (8000073402)

Standards	
RCM conformity	CE1T4581en_C1 ³⁾ (8000069574)
UL, cUL	UL 873 http://ul.com/database
EAC compliance	Eurasien compliance for all SAS variants

Environmental compatibility	
	The product environmental declarations CE1E4581en ³⁾ and A6V101083254 ³⁾ contain data on environmentally compatible product design and assessments (RoHS compliance, material composition, packaging, environmental benefit, and disposal).

Dimensions / Weight	
	Refer to "Dimensions"

Accessories ⁴⁾		
Auxiliary switch ASC10.51	Switching capacity	AC 24...230 V, 6 (2) A, potential free
	External supply line fusing	See "Power supply"
	US installation, UL & cUL	AC 24 V class 2, 5 A general purpose

1) AWG = American wire gauge.

The planner/installer is responsible for matching wire cross sections and fuses. Standard regarding protective measures – Note protection for overcurrent:

IEC 60364-4-43:2008 or German adoption HD 60364-4-43:2010.

2) For outdoor operation, always use weather shield ASK39.2, housing protection class IP 54 remains as is. SAS61../MO is not intended for outdoor use.

3) The documents can be downloaded via the Internet address, see Section "Product documentation".

4)

UL-approved component



Internal diagrams

<p>SAS31.0..</p> <p>AC 230 V Y1 Y2 M A N I 4041G01</p>	<p>SAS31.5..</p> <p>AC 230 V I21 Y1 Y2 M A N I 4041G07</p>	<p>Accessories, plug A 1x ASC10.51 ASC10.51 AC 24 V...230 V / 6 (2) A</p> <p>S1 S3 S2 4041G14</p>
<p>SAS61..</p> <p>AC/DC 24 V 4...20 mA DC 0...10 V AC/DC 24 V 0...1000 Ω G Y Z M A G0 U M DC 0...10 V 100% 0% 4041G03</p>		<p>Accessories, plug A 1x ASC10.51 ASC10.51 AC 24 V...230 V / 6 (2) A</p> <p>S1 S3 S2 4041G14</p>
<p>SAS61../MO</p> <p>AC 24 V / DC 24 V</p> <p>1 6 8 9 G REF + - M A G0 2 100% 0% A6V10137201_G01</p>		<p>Accessories, plug A 1x ASC10.51 ASC10.51 AC 24 V...230 V / 6 (2) A</p> <p>S1 S3 S2 4041G14</p> <p>US installation, UL & cUL AC 24 V class 2 5 A gen. purp.</p>
<p>SAS81.0..</p> <p>AC/DC 24 V Y1 Y2 M A G 4041G04</p>	<p>SAS81.33, SAS81.33U</p> <p>AC/DC 24 V G0 Y1 Y2 M A G 4041G08</p>	

Connection terminals

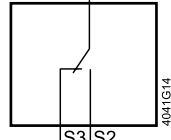
SAS31.0..		AC 230 V, 3-position	
4040Z17	N	System neutral (SN)	
	Y1	Positioning signal (actuator's stem extends)	
	Y2	Positioning signal (actuator's stem retracts)	
SAS31.5..		AC 230 V, 3-position	
4041Z82	N	System neutral (SN)	
	Y1	Positioning signal (actuator's stem extends)	
	Y2	Positioning signal (actuator's stem retracts)	
	Z1	Fail-safe function	
SAS61..		AC/DC 24 V, DC 0...10 V / 4...20 mA / 0...1000 Ω	
4040Z16	G0	System neutral (SN)	
	G	System potential (SP)	
	Y	Positioning signal for DC 0...10 V / 4...20 mA	
	M	Measuring neutral	
	U	Position feedback DC 0...10 V	
	Z	Positioning signal forced control AC/DC ≤ 24 V, 0...1000 Ω	
SAS61../MO		AC/DC 24 V, Modbus RTU connection cable	
4040Z59	G0	System neutral (SN)	black
	G	System potential (SP) AC 24 V ~ / DC 24 V =	red
	REF	Reference line (Modbus RTU)	violet
	+	Bus + (Modbus RTU)	gray
	-	Bus - (Modbus RTU)	pink
SAS81.0..		AC/DC 24 V, 3-position	
4040Z19	G	System potential (SP)	
	Y1	Positioning signal (actuator's stem extends)	
	Y2	Positioning signal (actuator's stem retracts)	
SAS81.33U		AC/DC 24 V, 3-position	
4041Z80	G	System potential (SP)	
	Y1	Positioning signal (actuator's stem extends)	
	Y2	Positioning signal (actuator's stem retracts)	
	G0	System neutral (SN)	
Electrical accessories			
ASC10.51		Auxiliary switch, adjustable switching positions, AC 24...230 V	
4040Z37	1	System potential (SP)	AC 24 V...230 V / 6 (2) A 
	2	Closes (actuator stem extends)	
	3	Opens (actuator stem extends)	

Connection diagrams

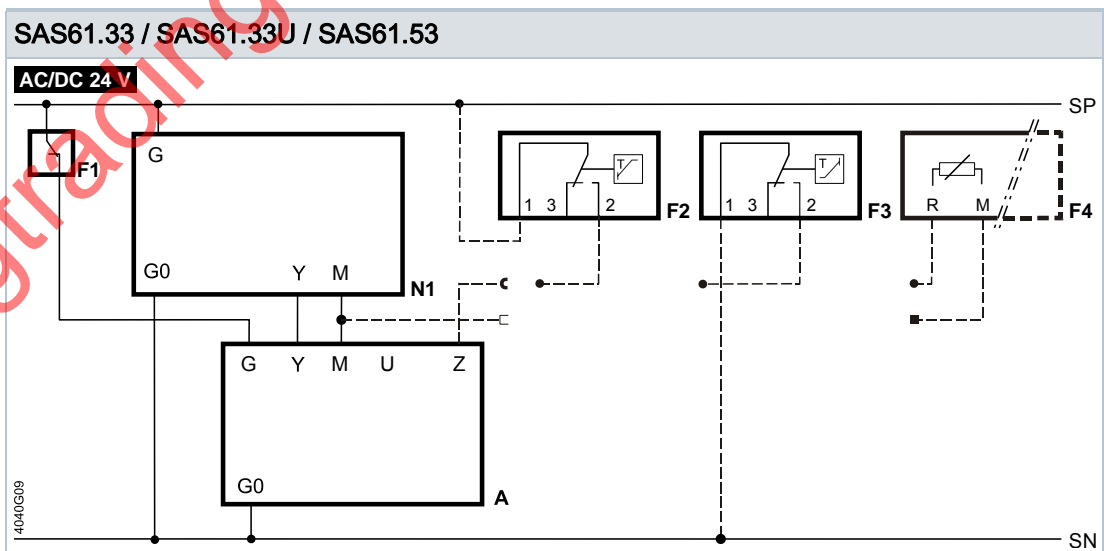
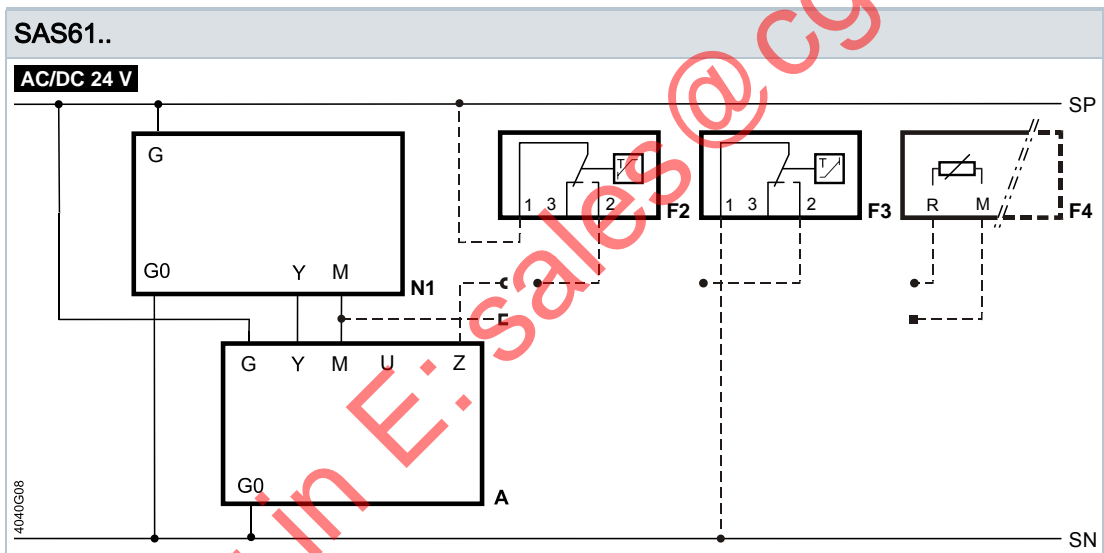
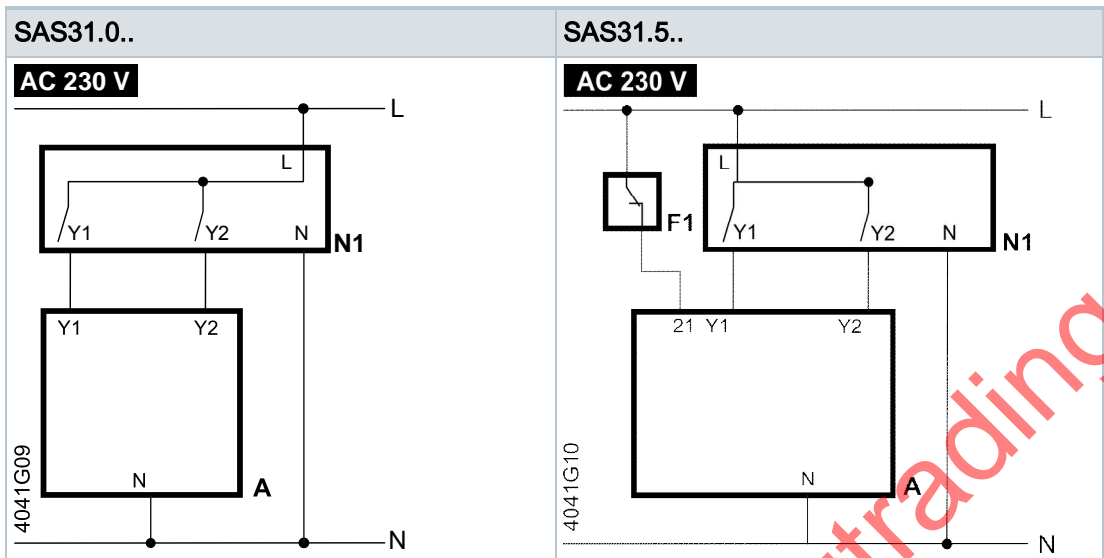

SAS61../MO

AC/DC 24 V

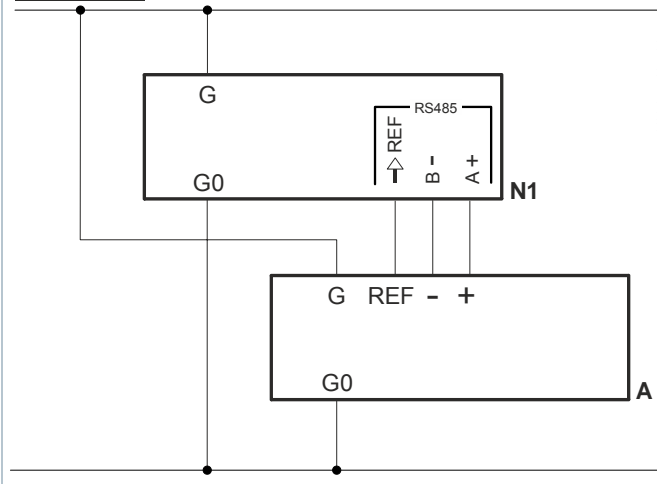

SAS81.0..

AC 24 V

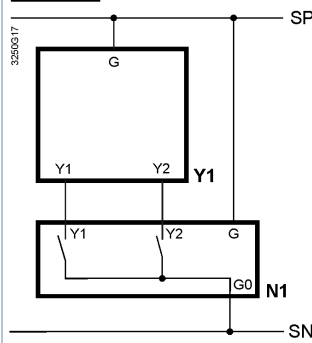

AC/DC 24 V

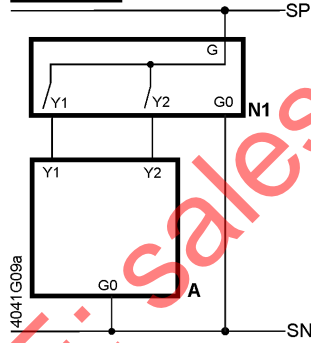

SAS81.33, SAS81.33U

AC/DC 24 V

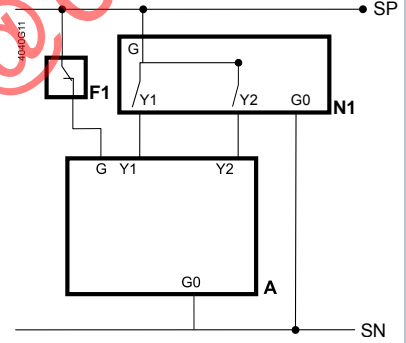

A	Actuator	REF	Reference line (Modbus RTU)
F1	Temperature limiter	SN	System zero
F2	Frost protection thermostat; terminals:1 – 2 Frost hazard / sensor is Off (thermostat closes upon frost) 1 – 3 normal operation	SP	System potential AC/DC 24 V
F3	Thermal reset limit thermostat	U	Position feedback
F4	Frost protection monitor with 0...1000 Ω signal output, does NOT support QAF21.. or QAF61..	Y	Positioning signal
G	System potential (SP)	Y1, Y2	Positioning signals
G0	System neutral (SN)	Z	Control signal forced control
L	Phase	21	Fail-safe function
M	Measuring neutral	+	Bus + (Modbus RTU)
N	Neutral	-	Bus - (Modbus RTU)
N1	Controller		

Actuators SAS.. with manual adjustment

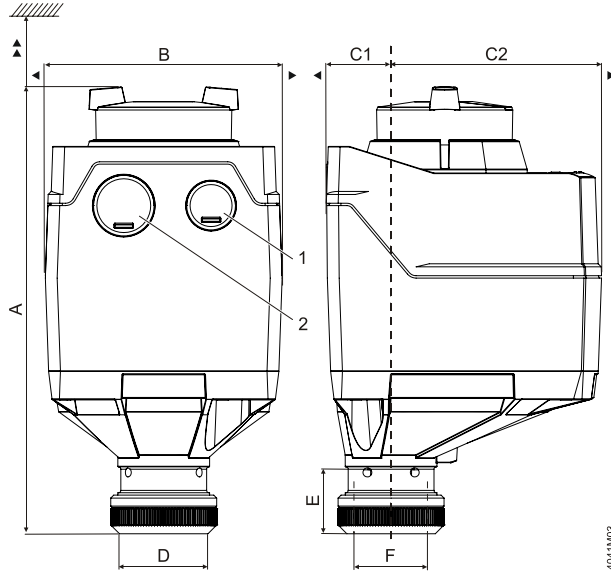

Type	A [mm]	B [mm]	C [mm]	C1 [mm]	C2 [mm]	D [mm]	E [mm]	F [inch]	▶ [mm]	▶▶ [mm]	kg [kg]	1	2
SAS..	151	80	93	21,9	71.1	29,9	21,8	G ¾	100	200	0,4	M16 ^{1) 3)}	M20 ^{1) 3)}
SAS../MO ²⁾											0,55		
With ASK39.2	155	126	248	99	149						0,55		

- 1) SAS..U: ½" (dia. 21.5 mm)
- 2) Device has fixed connection cable - left cable entry occupied
- 3) Thread length max. 9mm

Actuators SAS.. without manual adjustment

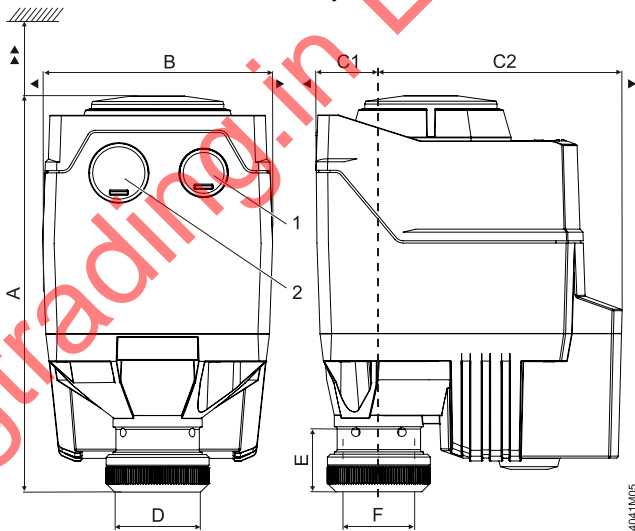

Type	A [mm]	B [mm]	C [mm]	C1 [mm]	C2 [mm]	D [mm]	E [mm]	F [inch]	▶ [mm]	▶▶ [mm]	kg [kg]	1	2
SAS..	137,6 ¹⁾ 151 ²⁾	80	106,5	21,9	84,6	29,9	21,8	G ¾	100	200	0,68	M16 ³⁾	M20 ³⁾
With ASK39.2	155	126	248	99	149						0,83		

- 1) Black cover
- 2) Blue handwheel
- 3) Thread length max. 9mm

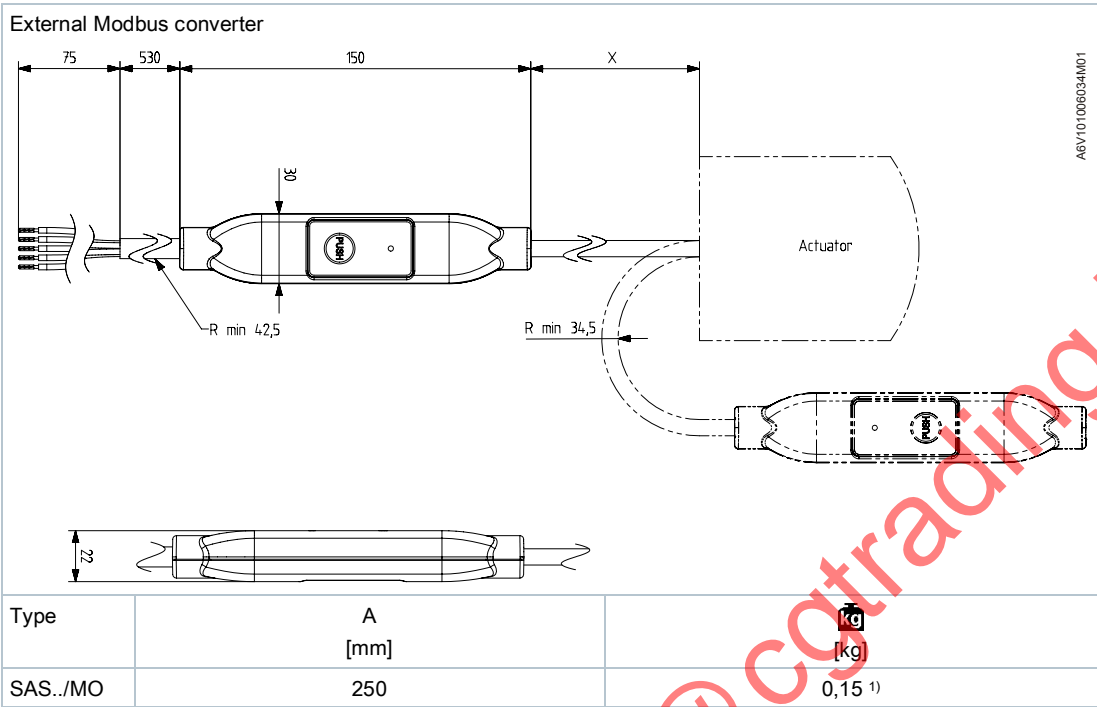

1) Included in total weight

Dimensions in mm

www.cgtrading.in E: sales@cgtrading.in

Revision numbers

Type	Valid from rev. no.
SAS31.00	..B
SAS31.03	..B
SAS31.50	..B
SAS31.53	..B
SAS61.03	..B
SAS61.03U	..B
SAS61.03/MO	..B
SAS61.33	..B
SAS61.33U	..B
SAS61.53	..B
SAS81.00	..B
SAS81.03	..B
SAS81.03U	..B
SAS81.33	..B
SAS81.33U	..B

Issued by
Siemens Switzerland Ltd
Building Technologies Division
International Headquarters
Gubelstrasse 22
CH-6301 Zug
Tel. +41 58-724 24 24
www.siemens.com/buildingtechnologies

© Siemens Switzerland Ltd, 2015
Technical specifications and availability subject to change without notice.